



L-16 Crank-Up Lift

**Instruction &
Operation
Manual**

722 Blue Crab Road Newport News VA 23606
Toll Free 800-883-0008 Phone 757-591-9371 Fax 757-591-9514

WINCH INSTALLATION

- READ THIS FIRST -

- (1) Remove winch and leveling pads from shipping box attached to main tube. The winch is shipped with the steel cable attached and completely threaded through the lift assembly.
- (2) Attach winch to platform mounting channel using (3) 3/8" x (3) 1-1/4" bolts provided. See figure 1 below.
- (3) Place bolts through holes and hold in place.
- (4) Place winch over bolts and secure with 3/8" flat washers and 3/8" self-locking nuts.
- (5) Install leveling pads to the bottom of each fold-out leg. (See page 3 for details).
- (6) Continue with operation instructions on page 2.

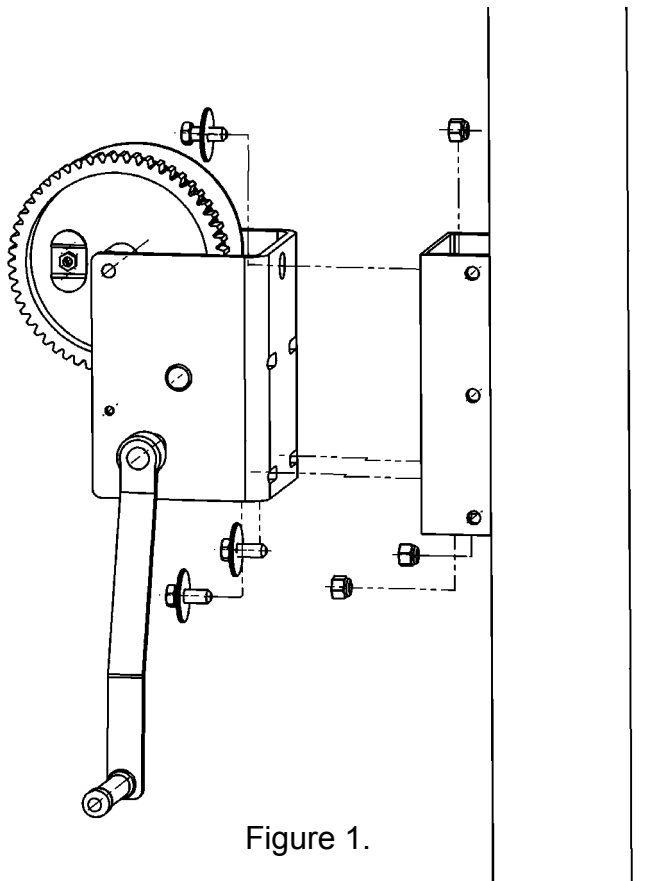

Figure 1.

OPERATION

- (1) Remove locking pin holding each leg in the folded position. Fold the legs down and re-insert locking pins through the leg braces.
- (2) The central mast is the main load supporting element.
- (3) Adjust the leveling pads at the end of each leg so that the lift is vertically straight and level. Make sure to eliminate any slack between the legs and braces. Leveling pads should not be adjusted so that the central mast does not rest solidly on the ground.
- (4) Inspect the cable to make sure that none of the wires are frayed or that the cable itself has not been crushed.
- (5) Test the lift to see that no damage has been incurred that would bind the moving pieces of the system.
- (6) Secure the load to your lift in a proper fashion being careful to have a positive fastening.
- (7) If two or more lifts are being used simultaneously, all lifts must be raised evenly.
- (8) Three safety pins are provided for use when raising and lowering the lift. These must be used to insure safety in the event of cable failure. As you raise the lift, insert a safety pin into the first hole in the 2" tube. Then insert a 2nd pin into the next hole down as it becomes visible. When the 3rd hole becomes available, remove the first safety pin and insert it into the 3rd hole. Continue to alternate pins through the holes until the second stage begins to rise. Leave a pin in the last hold of the 2" tube. Using the two remaining pins, repeat the above procedure inserting pins in the 3" tube for lifts above 12 ft. To lower the system, follow the above procedures in reverse order.

NOTE: MAKE SURE THAT THE WINCH IS RATCHETING AS YOU CRANK. IF THIS FAILS TO HAPPEN, LOWER THE LIFT SLIGHTLY AND THEN RAISE IT AGAIN UNTIL YOU HEAR IT CLICK BEFORE RELEASING THE HANDLE. IF THIS OCCURS, THE WINCH MAY NEED TO BE ADJUSTED INTERNALLY.

WARNING: KEEP HANDS FREE OF UPPER TUBES WHILE RAISING AND LOWERING LIFT!

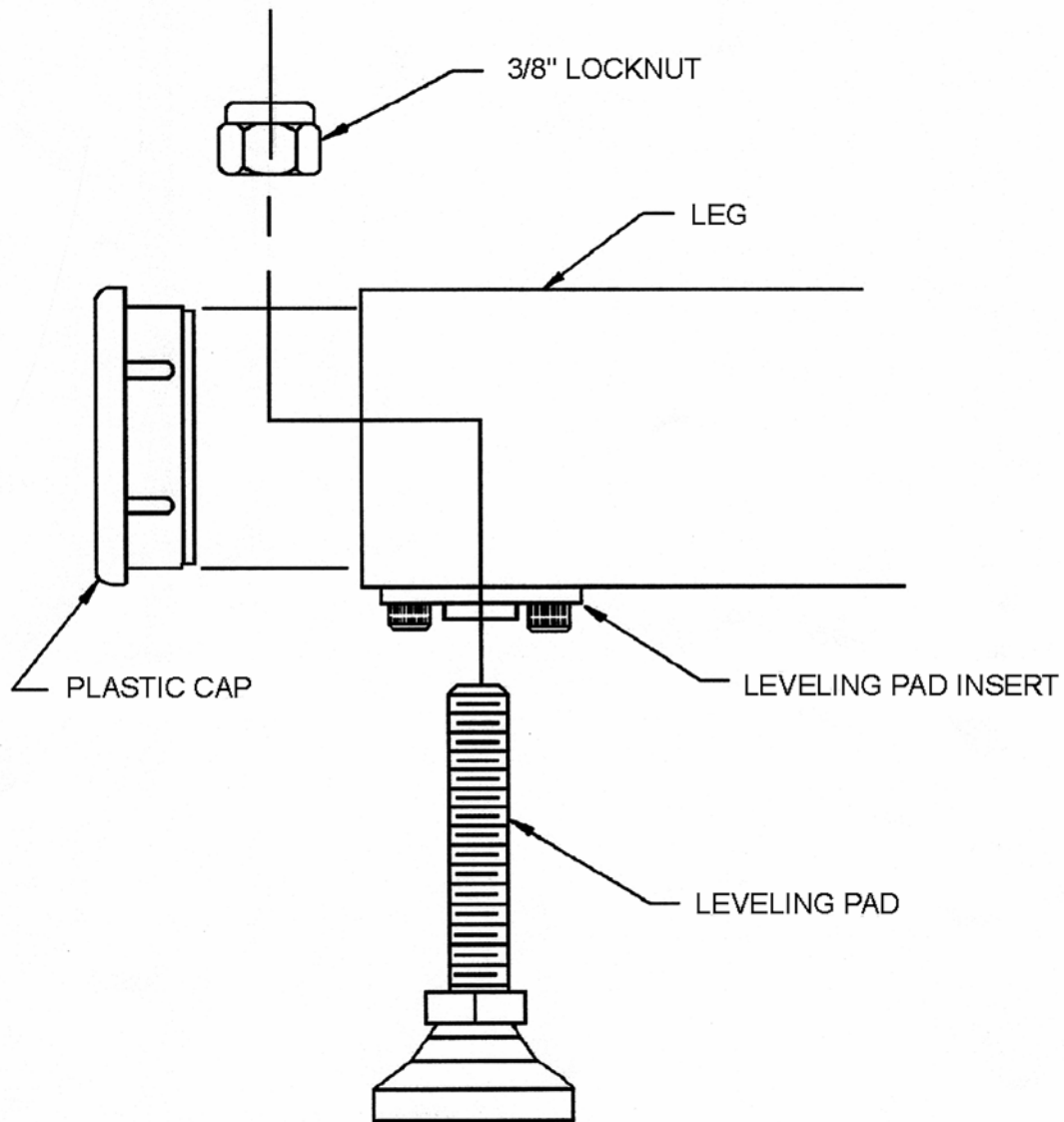

THREAD LEVELING PAD INTO THE LEVELING PAD INSERT ON LEG. THREAD 3/8" LOCKNUT ONTO THE END OF THE LEVELING PAD STUD UNTIL 1-1/2 THREADS SHOW THROUGH THE TOP OF THE NUT. PRESS BLACK PLASTIC CAP INTO THE END OF THE TUBE.

MAINTENANCE

The steel cable deserves and requires the most attention as it is the means by which the load is able to move up and down. The proper cable for this application is supplied, but it is up to you to inspect and maintain it regularly.

- (1) Keep the cable lubricated periodically to avoid oxidation. Any light duty oil or silicone based lubricant will do just fine.
- (2) Lubricate the pulleys frequently to prevent premature wear. The same lubricant used on the cable will be sufficient for this application.
- (3) If the cable shows any sign of fraying, wear, or deformation – order a replacement from your authorized Applied Electronics dealer or distributor.
- (4) Inspect the ball and shank that is swaged to the top end of the cable. See that the cable always remains flush to the outside of the ball.
- (5) Always replace any bent or broken parts immediately. These are available and should be purchased through the Applied Electronics dealer network.
- (6) Individually push the 2” and the 3” tubes to one side in both directions and check the gap between the tube and the bushing material that surrounds the tube at the top of each larger tube. If the gap ever becomes greater than .035”, then new material should be ordered to replace the worn material. This gap measurement can be handled quickly and effectively with a standard feeler gauge.
- (7) To replace the cable, follow the cable routing diagram in fig. (A) page 5. Be sure to keep the tubes in the same alignment orientation. Termination of the cable to the winch should be done as shown in fig. (B) page 5.
- (8) In order to insure extended winch performance, occasionally grease gears, reel shaft and handle threads. An occasional drop of oil on drive shaft bearings is also recommended.

DO NOT OIL OR GREASE WINCH BRAKE MECHANISM.



DLB1200A & DLB1200AG Winch

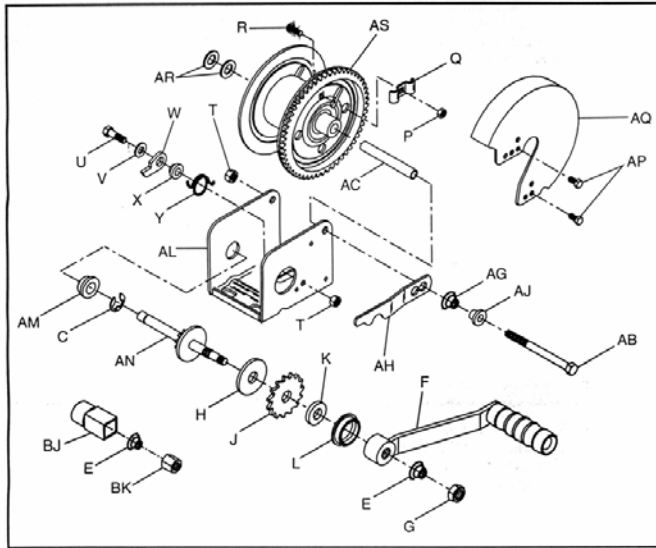

WINCH INSTRUCTION PAGE

WARNING READ INSTRUCTIONS CAREFULLY BEFORE ATTEMPTING TO INSTALL, OPERATE OR SERVICE THIS WINCH. FAILURE TO COMPLY WITH INSTRUCTIONS COULD RESULT IN SERIOUS OR FATAL INJURY. RETAIN THESE INSTRUCTIONS FOR FUTURE REFERENCE.

IMPORTANT SAFETY INFORMATION

- This brake winch is built for multi-purpose hauling and lifting operations. It is not to be used as a hoist for lifting, supporting or transporting people, or for loads over areas where people could be present.
- Respect this winch. High forces are created when using a winch, creating potential safety hazards. It should be operated and maintained in accordance with instructions. Never allow children or anyone who is not familiar with the operation of the winch to use it. A winch accident could result in personal injury.
- Check winch for proper operation on each use. Do not use if damaged. Seek immediate repairs.
- Never exceed rated capacity. Excess load may cause premature failure and could result in serious personal injury. This winch is rated on first layer of cable on the hub. Using more layers of cable increases the load on the winch.
- Never apply load on winch with cable fully extended. Keep at least three full turns of cable on the reel.
- Secure load properly. When winching operation is complete, do not depend on winch to support load.
- Operate with hand power only. This winch should not be operated with a motor of any kind. If the winch cannot be cranked easily with one hand, it is probably over-loaded.

PARTS LIST

Ref	Description	Part No.	Ref	Description	Part No.
A	Base	404900	AF	Base	404893
A	Base – DLB 350AG	404945	A	Base – DLB 800AG	404895
B	Bushing	204012	AG	Spring (optional)	204364
C	"E" Ring	205116	AH	Lockout Lever (optional)	404579
D	Drive Shaft	304758	AJ	Spacer (optional)	404166
E	Spring	204364	AK	Gear Cover (optional)	404271
F	Handle	304231	AL	Base	404896
F	Handle – DLB 1200AG	304232	AM	Base – DLB 1200AG	404897
G	Nut	205015	AM	Bushing	204009
H	Pressure Plate	204362	AN	Drive Shaft	304759
J	Ratchet Wheel	404164	AP	Screw (optional)	205189
K	Pressure Washer	404163	AQ	Gear Cover (optional)	404044
L	Bushing	206328	AR	Spacer Washer	204360
M	Nut	205316	AS	Reel	304754
N	Bolt	205332	AS	Reel – 1-7/8" (optional)	304768
P	Nut	206225	AT	Base	404891
Q	Rope Clamp	404043	A	Base – DLB 1500AG	404892
R	Carriage Bolt	205017	AU	Drive Shaft	304760
R	Carriage Bolt – 3/4" Lg.	205215	AV	Handle	304232
S	Reel	304790	A	Handle – DLB 1500AG	304265
T	Locknut	204803	AX	Reel Spacer	204808
U	Bolt	205167	AY	Gear Cover (optional)	404272
V	Flat Washer	205055	AZ	Reel	304755
W	Pawl	404409	BA	Base	404898
W	Pawl – "G" Series	404190	BA	Base – DLB 2000AG	404899
X	Spacer	404166	BB	Spacer	404434
X	Spacer – "G" Series	404191	BC	Bolt	205006
Y	Spring	204363	BD	Spacer	404911
Y	Spring – "G" Series	204460	BE	Intermed. Drive Shaft	304761
Z	Reel Spacer	207183	BF	Nut	205014
AB	Bolt	203161	BG	Bolt	204804
AC	Reel Spacer	204807	BH	Reel	304756
AE	Reel	304753	BJ	Drive Hub (Optional)	304562
			BK	Hex Nut (Optional)	404485
			BL	Handle Brk. Assy (Opt)	304795
			BM	Handle (Optional)	304638
			BN	Handle Hub (Optional)	304630
			BP	Slotted Nut (Optional)	404970

ASSEMBLY – Thread the handle onto the winch drive shaft and be certain that a clicking noise is produced when the handle is turned clockwise. Install the spring and locknut (Items E and G) on the end of the drive shaft as shown on parts drawing. These parts may appear to serve no function, but they provide several important fail-safe features, and should not be altered or removed.

OPERATING INSTRUCTIONS – Wind cable on winch reel by turning winch handle in clockwise direction. This should produce a loud, sharp, clicking noise. The load will remain in position when the handle is released. Wind cable off the winch reel by turning winch handle counterclockwise (no noise will be produced). The load will remain in position when the handle is released, but for extra security it is recommended that the handle be turned clockwise until at least two clicks are heard. This will add extra tightness to the brake mechanism. Always satisfy yourself that the winch is holding the load before releasing the winch handle.

IMPORTANT: Sufficient load must be applied to the cable to overcome internal resistance and operate the brake properly, otherwise turning the crank handle counterclockwise will only remove the

WINCH MOUNTING AND CABLE ATTACHMENT – For maximum strength and safety, this winch should be mounted with three 3/8" bolts (M10), washers and lock washers. (See parts drawing). Using fewer bolts or alternate locations will result in damage to the winch base and the winch may malfunction.

Attach cable or rope by either method shown in sketch.

handle from the shaft – the reel will not turn. The minimum operating load requirement is 50 lb (23 kg) for Models DLB350A, DLB350AG, DLB800A, DLB800AG, DLB1200A and DLB1200AG, 75 lb (34 kg) for DLB1500A and DLB1500AG, 175 lb (80 kg) for DLB2000A and DLB2000AG.

Models DLB805A, DLB1205A, & DLB1505A, are equipped with a lockout lever for the purpose of "freewheeling" cable out when there is no load on the winch. To "freewheel" cable out, simply turn the handle counterclockwise until lockout lever can be engaged behind handle hub. In this condition cable can be easily pulled from the winch drum.

WARNING: Never put winch in freewheel mode if any potential for a load on the cable exists. Engaging the lockout lever keeps the winch from stopping in the event that a load is accidentally applied.

WINCH MAINTENANCE – In order to insure maximum performance, a periodic inspection for any necessary preventive maintenance should be made. Check at least once annually and more frequently when the winch is exposed to an environment which is particularly dirty or wet. For continued smooth performance and increased life, occasionally grease gears,

reel shaft and handle threads. An occasional drop of oil on the drive shaft bearings is also recommended. **NOTE: Do not oil or grease brake mechanism.**

Keep winch in good working order. Damaged or severely-worn parts create unnecessary dangers and could result in personal injury or property damage.

NOT FOR THE MOVEMENT OF HUMAN BEINGS

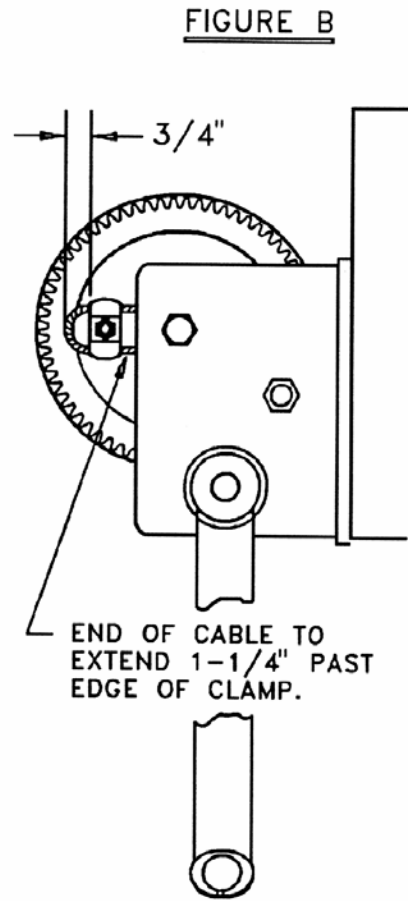
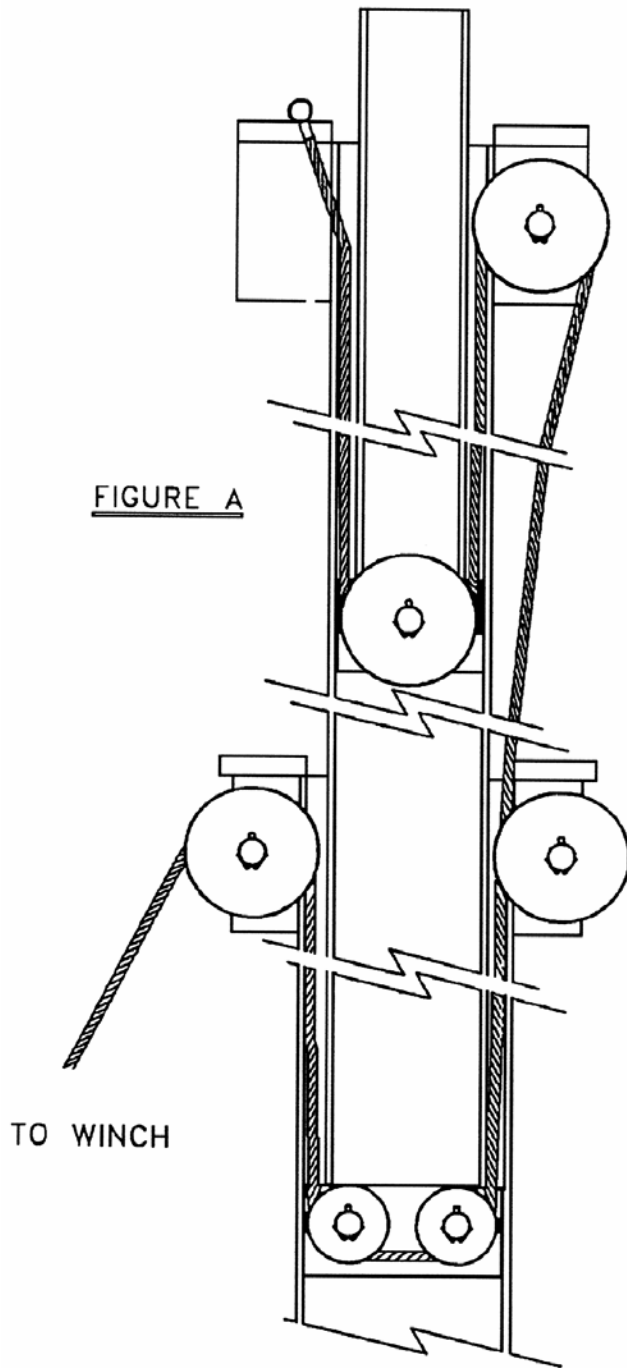

SPECIFICATIONS

- Three Section 16 ft. Crank-Up Lift
- 500 lb. Load Maximum at 6' Through 16'
- 6 1/2' Loading Height
- 16' Maximum Lift Height
- 84" Base Diameter For Stability
- 6 1/2' Collapsed Length
- 18" Collapsed Diameter
- 95 lbs. Total Weight
- 3/16" Steel Cable

FIELD REPLACEMENT PARTS

PART NUMBER	DESCRIPTION
91-505	Winch, DLB1200A
91-501	Cable, 3/16" 7 x 19 GAC With Ball and Shank
91-316	Brace End Cap 1-1/2" x 2"
91-317	Leg End Cap 2 x 2
91-025	Leveling Pad/Foot
91-026	Leveling Pad Insert, Brass
91-310	Clevis Pin, 1/2" x 1-1/2"
91-301	Mast Pin, 3/8" x 4-1/2" Quick Release
91-300	Leg Pin, 3/8" x 3-1/2" Quick Release w/T Handle
91-023	Pulley, 1-1/2" DIA With Bushing
91-024	Pulley, 2-1/2" DIA With Bushing
81000076	Upper Bushing Material, 1" x 2"
81000077	Upper Bushing Material, 1" x 2-3/4"
82000122	Lower Bushing Material, 1" x 2"
82000123	Lower Bushing Material, 1" x 2-3/4"