

# Mini Controller

for the

# DATAFLASH<sup>®</sup>

●●::AF1000::●●

## Xenon Strobe Fixture

## User's Manual

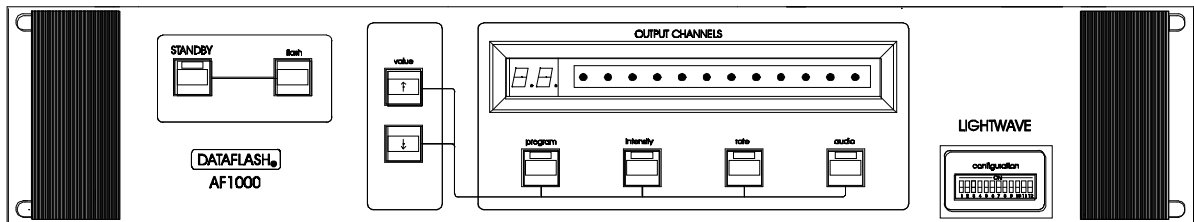

High End Systems Inc.  
2217 West Braker Lane  
Austin, Texas U.S.A.



© High End Systems, Inc. 1995, All Rights Reserved

Information and Specifications in this document are subject to change without notice. High End Systems, Inc. assumes no responsibility or liability for any errors or inaccuracies that may appear in this manual.

Unlawful reproduction or distribution in any manner without the written permission of High End Systems is strictly forbidden.

Trademarks used in this text: *DATAFLASH*, *Lightwave Research*, and the *Lightwave Research logo* are registered trademarks; and *High End Systems* and the High End Systems Logo are trademarks of High End Systems Inc.

Other trademarks and trade names may be used in this document to refer to either the entities claiming the marks and names or their products. High End Systems disclaims any proprietary interest in trademarks and trade names other than its own.

February, 1997

*Mini Controller for the DATAFLASH AF1000 Xenon Strobe Fixture User's Manual*  
P/N 60600045 Rev. A1

Printed in the U.S.A.  
M.D.T.

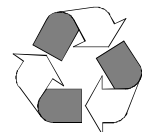

# Table of Contents

<b>Introduction.....</b>	<b>Intro-1</b>
About This Manual .....	Intro-1
Text Style .....	Intro-1
Caution and Warning Symbols .....	Intro-1
Safety Instructions .....	Intro-2
Overview.....	Intro-2
Features .....	Intro-2
Specifications.....	Intro-2
Getting Help.....	Intro-3
Mini Controller Reference .....	Intro-4
<b>Chapter 1</b>	
<b>Installation and Setup.....</b>	<b>1-1</b>
Unpacking.....	1-1
Save the Shipping Materials .....	1-1
Inspect the Contents.....	1-1
Before You Begin .....	1-2
System Configuration and Set Up .....	1-2
AF1000 Switch Settings .....	1-2
Mini Controller Switch Settings .....	1-4
System Set Up and Cabling .....	1-4
<b>Chapter 2</b>	
<b>Mini Controller Operation.....</b>	<b>2-1</b>
Overview.....	2-1
Operating Process .....	2-1
Standby Mode .....	2-2
Flash Mode .....	2-2
Program Mode .....	2-2
Program Hold.....	2-3
Program Select Return .....	2-3
Standard Programs .....	2-3
Random Function Programs .....	2-4
Advance Programs .....	2-4
Lightning Programs .....	2-4
Intensity .....	2-5
Incremental .....	2-5
Program Function .....	2-5
Function Advance .....	2-5
Rate .....	2-6
Incremental .....	2-6
Program Function .....	2-6
Function Advance .....	2-6

Audio Mode .....	2-7
Audio Parameters.....	2-7
Audio Rate or Intensity Manipulation .....	2-8

## **Appendix A**

### **Troubleshooting and Maintenance..... A-1**

Support Checklist.....	A-1
Possible Problems and Solutions .....	A-2
Mini Controller Reset .....	A-3
Mini Controller ROM Version Number .....	A-3
General Maintenance and Cleaning .....	A-3

## **Appendix B**

### **Warranty Information ..... B-1**

### **Addendum ..... ADM-1**

Program Mode .....	ADM-1
Standard Programs.....	ADM-1
Random Function Programs .....	ADM-13
Advance Programs .....	ADM-13
Lighting Programs .....	ADM-13
Intensity Parameters.....	ADM-14
Rate Parameters .....	ADM-14
Audio Parameters.....	ADM-15

## **Figures**

Figure 1. Front and Rear Panels of the MiniController .....	Intro-4
Figure 1.1 DIP Switch Location .....	1-4
Figure 1.2 XLR Pin Configuration. ....	1-4
Figure 1.3 System Cabling .....	1-5
Figure 1.4 Audio Cabling .....	1-5
Figure 1.5 Connecting the Audio Cable .....	1-6
Figure 2.1 Mini Controller Operation Process.....	2-2
Figure 2.2 Audio Parameter Display .....	2-7

## **Tables**

Table 1.1 Intensity/Duty Cycle Settings .....	1-2
Table 1.2 DMX Address Switch Setting .....	1-3
Table 2.1 Standard Programs Per Channel .....	2-3
Table 2.2 Intensity Program Functions .....	2-5
Table 2.3 Rate Program Functions .....	2-6
Table 2.4 Audio Rate or Intensity Manipulation Functions .....	2-8
Table A.1 Trouble Shooting Solutions .....	A-2
Table ADM.1 Available Programs for One Fixture .....	ADM-1
Table ADM.2 Available Programs for Two Fixtures .....	ADM-2
Table ADM.3 Available Programs for Three Fixtures .....	ADM-3

Table ADM.4 Available Programs for Four Fixtures .....	ADM-4
Table ADM.5 Available Programs for Five Fixtures.....	ADM-5
Table ADM.6 Available Programs for Six Fixtures .....	ADM-6
Table ADM.7 Available Programs for Seven Fixtures .....	ADM-7
Table ADM.8 Available Programs for Eight Fixtures .....	ADM-8
Table ADM.9 Available Programs for Nine Fixtures .....	ADM-9
Table ADM.10 Available Programs for Ten Fixtures .....	ADM-10
Table ADM.11 Available Programs for Eleven Fixtures.....	ADM-11
Table ADM.12 Available Programs for Twelve Fixtures.....	ADM-12
Table ADM.13 Advance Programs .....	ADM-13
Table ADM.14 Lightning Programs .....	ADM-13
Table ADM.15 Random Functions .....	ADM-13
Table ADM.16 Intensity Parameters.....	ADM-14
Table ADM.17 Rate Parameters .....	ADM-14
Table ADM.18 Audio Parameters.....	ADM-15



# Introduction

Congratulations and thanks for selecting the *Mini Controller for the DATAFLASH® AF1000 Xenon Strobe Fixture* from Lightwave Research®.

## About This Manual

---

This manual provides the means to setup and operate *Mini Controller*. This manual is organized in the following sections:

**Introduction**—introduces you to this manual, the *Mini Controller*, provides hardware specifications, and technical support information.

**Chapter 1 Installation and Setup**—explains how to install the *Mini Controller*.

**Chapter 2 Operation**—explains how to configure, program, and play back data.

**Appendix A Troubleshooting and Maintenance**—provides directions for troubleshooting problems and general maintenance of your controller.

**Appendix B Warranty Information**—provides information on the *DATAFLASH® AF1000 Mini Controller* warranty.

**Addendum**—provides the contents of the existing programs.

## Text Style

---

Throughout this manual, different types of text will be used to refer to its corresponding item:

- a reference to specific key will look like: push the <STANDBY> button
- a reference to a DIP switch will look like: DIP switch <1>
- a reference to the LED display will look like: A A

## Caution and Warning Symbols

---

The following international symbols appear in margins throughout this manual to highlight caution and warning messages.



**Caution:** This symbol appears adjacent to Caution messages. Ignoring these messages could result damage to equipment.



**Warning:** This symbol appears adjacent to High Voltage Warning messages. Ignoring these messages could result in serious personal injury.

## Safety Instructions

---

- Heed all caution and warning messages throughout this manual and the documentation that accompanies your *AF1000* strobes.
- Servicing must be conducted by the manufacturer or other qualified service personnel. There are no user serviceable parts inside.

## Overview

---

The *Mini Controller* for the *DATAFLASH AF1000* strobes is a powerful compact device that can control up to 12 channels of *AF1000* strobes through 24 channels of USITT DMX-512 protocol. The intensity levels of the applicable channels are conveniently displayed by 12 LEDs. All programs can be edited for live control of the *AF1000* strobes.

## Features

---

- Up to 45 programs per channel
- Controls up to 12 channels of *AF1000* strobes
- 64 intensity steps
- 99 rate steps
- 7 Lightning effect programs
- 30 Audio synchronization and triggering parameters
- Program Hold Mode
- Two year warranty

## Specifications

---

Height:	8.9 cm (3.5 in.)
Width:	48.2 cm (18.97 in.)
Depth:	6 cm (2.36 in.)
Weight:	1.9 Kg (4.18 lbs.)
Power Consumption:	13 W (100 mA) at 120 VAC (60 Hz.) 16 W (50 mA) at 240 VAC (50 Hz.)
Audio Input:	100 mV to a maximum of 1 V peak to peak

## **Getting Help**

---

High End Systems Service provides a help line should you encounter any problems during your installation or initial operation. Currently, service hours are 9 a.m. to 6 p.m. (Central), Monday through Friday. The numbers are:

Voice lines: (512) 837-3063 or (800) 890-8989

Fax line: (512) 834-9195

# Mini Controller Reference

Figure 1. Front and Rear Panels of the Mini Controller

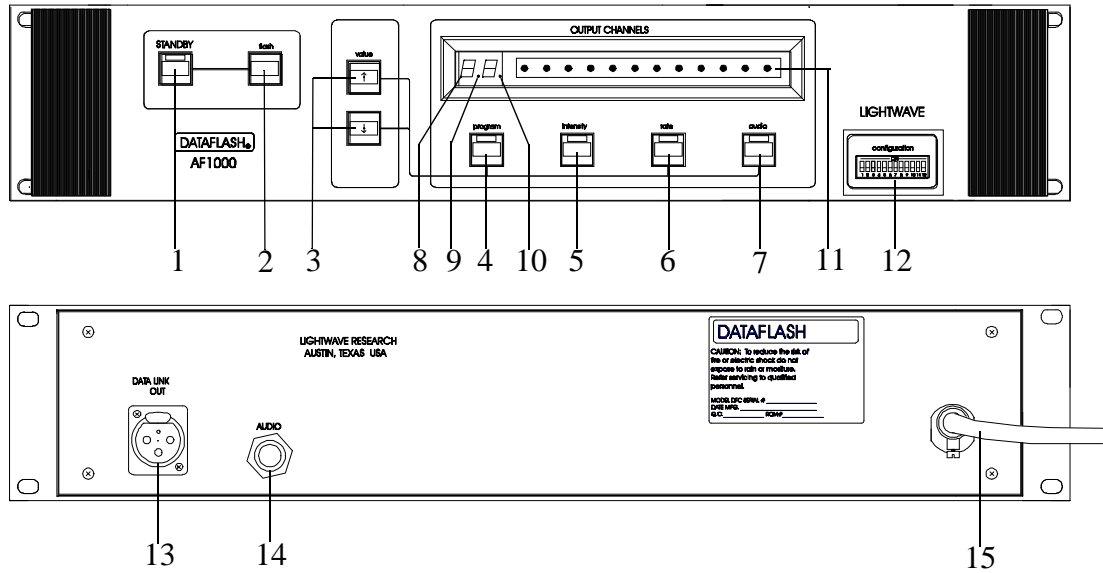

- |                                 |  |
|---------------------------------|--|
| 1. <STANDBY>                    | disables controller output of programs   |
| 2. <flash>                      | when held down, causes all connected strobes to flash at full intensity for .15 seconds at 50 Hz. and .125 seconds at 60 Hz. |
| 3. Up/down arrow keys           | increments values up/down  |
| 4. <program>                    | provides access to current program, Program Advance Mode, and Program Hold Mode  |
| 5. <rate>                       | provides access to the Rate parameters   |
| 6. <intensity>                  | provides access to the Intensity parameters  |
| 7. <audio>                      | provides access to the audio parameters  |
| 8. Value display                | displays the current value or mode via two 7-segment LEDs  |
| 9. Program hold indicator LED   | when lit, Program Hold Mode is in use  |
| 10. Audio beat indicator LED    | indicates that an audio signal is present, the rate of the beat, and the strength of the audio signal                        |
| 11. Output channel display LEDs | indicates the intensity and operation of the applicable channels   |
| 12. Configuration DIP switches  | selects the number of output channels  |
| 13. Data Link Out               | 3-pin female XLR connector that provides serial DMX data to the strobes  |
| 14. Audio Input                 | 1/4-inch stereo input jack   |
| 15. Line cord                   | <i>Mini Controller</i> AC power cable  |



# Chapter 1

## Installation and Setup

In this chapter you will:

- unpack the Mini Controller*
- configure AF1000 strobes*
- configure Mini Controller*
- install the controller's cables*

### Unpacking

---

In this section you unpack your *Mini Controller* and verify that it arrived complete and without any damage.

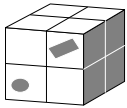

#### Save the Shipping Materials

---

**Do not discard** the shipping cartons and packing materials. These cartons and packing materials are specifically designed to protect the controller during transport.

If you ever need to ship this product for repair or maintenance, please return it in its original shipping carton and packing materials. You will be billed for a new shipping carton and new packing materials if you return your controller in a non-factory shipping carton with non-factory packing materials.

**Note:** Before returning anything to the factory, be sure to call your High End Systems Dealer/Distributor for a Return Authorization Number. The factory cannot accept any goods shipped without an RA number.

#### Inspect the Contents

---

The *Mini Controller* arrives in one carton, which contains the controller and this manual. If the controller was damaged in shipping, you must notify both the shipping agent and your sales agent immediately.

## Before You Begin

---



**Caution:** Before you begin the installation read the following safety precautions.

1. Read all warnings, precautions, and safety instructions listed in *AF1000 User Manual*.
2. Check the label on the back of the controller to ensure that the voltage is correct for your location.
3. Do not place the *Mini Controller* on the same circuit with the *AF1000* strobes, as doing so may result in erratic actions by the controller.
4. Do not use **DATAFLASH** strobes with this controller. This controller is designed to operate **DATAFLASH AF1000** strobes only. Protocol differences will result in erratic fixture behavior and possible component damage.
5. Do not mix the operational modes of the *AF1000* strobes. Refer to the *AF1000 User Manual* for further information.

## System Configuration and Set Up

---

This section covers the Configuration of the *Mini Controller*. Take careful consideration for the placement of the strobes. The programs were specifically designed for linear (1,2,3, etc.) (left to right, right to left) operation.

### AF1000 Switch Settings

---

For the *Mini Controller* to properly operate the *AF1000* strobes, the Personality and Address DIP switches on the *AF1000* strobes must set. For information on accessing these switches, refer to your *AF1000 User Manual*. The Personality switches on each strobe must be set for the same intensity/duty cycle. Refer to Table 1.1.

Table 1.1: Intensity /Duty Cycle Settings

Setting	Personality Switch On
Standard	None
Architectural	6
Special Effect	7

**Note:** while mixed operational modes will work together, the fixtures will respond at different intensities, causing the programs look differently then they were designed.

Next, each strobe must be set for two channel DMX mode. This is accomplished by setting Personality switches <3> and <4> to the On position (switch <5> must be in the off position).

Finally, set the fixture address switches to 1–23 (depending upon how many fixtures you have). Refer to Table 1.2 for the appropriate settings.

*Table 1.2: DMX Address Switch Setting*

<b>Fixture Number</b>	<b>DMX Channel</b>	<b>Address Switches On</b>
1	1	none
2	3	2
3	5	3
4	7	2, 3
5	9	4
6	11	2, 4
7	13	3, 4
8	15	2, 3, 4
9	17	5
10	19	2, 5
11	21	3, 5
12	23	2, 3, 5

**Notes:** if a DMX channel is accidentally set for an even channel number, the Intensity and Rate functions will be reversed causing the strobe to behave erratically. The *Mini Controller* can control more than twelve strobes, but additional *AF1000* strobes must be set at duplicate addresses with other existing strobes.

## Mini Controller Switch Settings

---

The DIP switches on the *Mini Controller* must be properly set so the controller can send the correct data packets to the number of available fixtures. If power has already been applied to the controller, the seven-segment LEDs will blink C F (configure) until a DIP switch is set. The DIP switches are located on the front panel of the *Mini Controller* in the lower right-hand corner. Refer to Figure 1.1.

Figure 1.1. DIP Switch Location

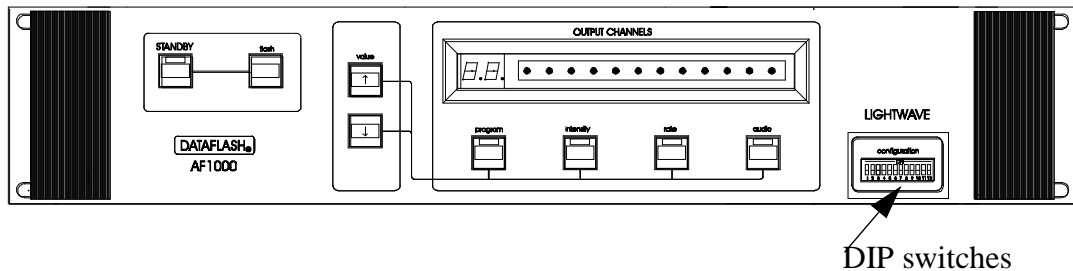

To set the DIP switches, simply turn on the switch that corresponds to the number of available *AF1000* strobes. For example, if you have eight strobes, set switch <8> to the On position and leave all other switches in the Off position.

**Note:** if two or more DIP switches are accidentally set to the On position, the highest number DIP switch will take precedence.

## System Set Up and Cabling

---

Secure your *Mini Controller* in a standard 19-inch rack or place it on a flat surface. If you are unsure about how your XLR cables are constructed, use Figure 1.2 and a Volt Ohm Meter to verify correct installation. Using the Volt Ohm Meter, place the terminals on each pair of corresponding pins to ensure that there is extremely little or no resistance in the line.

Figure 1.2. XLR Pin Configuration

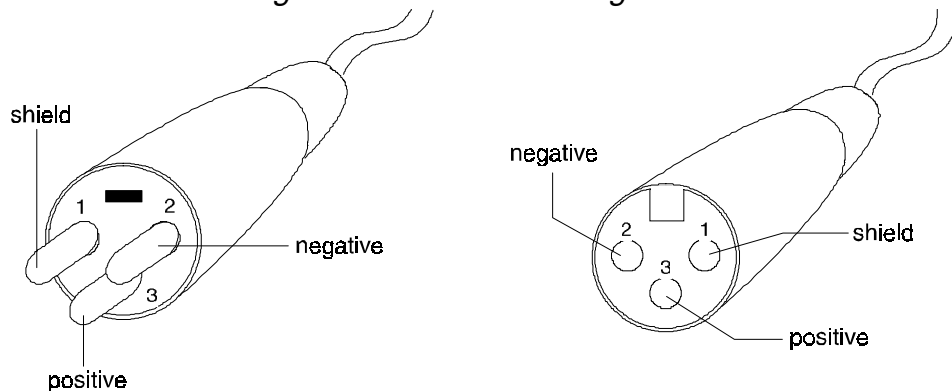

Connect an XLR cable to the rear of the *Mini Controller* and run it to the first *AF1000*. Daisy chain the desired number of fixtures together. Refer to Figure 1.3.

**Note:** fixture termination is not required.

Figure 1.3. System Cabling

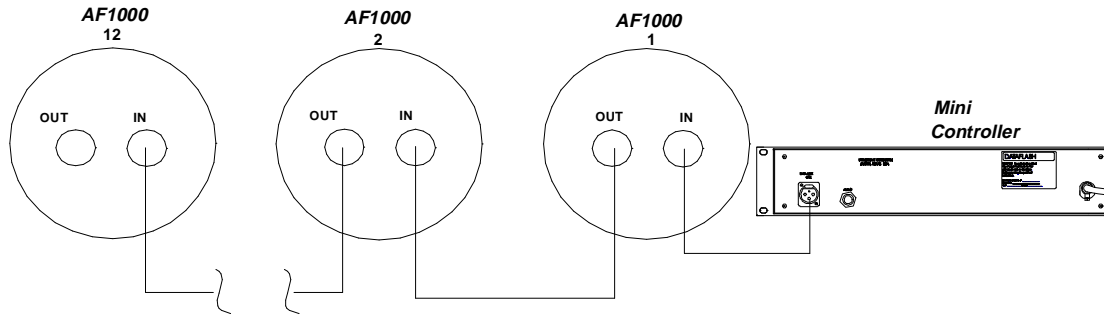

If you intend on using the audio synchronization, connect a 1/4-inch mono male (tip, ring) phone connector or 1/4-inch stereo male (tip, ring, sleeve) phone connector to the Audio input jack on the rear of the connector. Refer to Figure 1.4 for correct cable wiring.

Figure 1.4. Audio Cabling



Connect the other end of the cable to an unused audio mixer output. Refer to Figure 1.5.

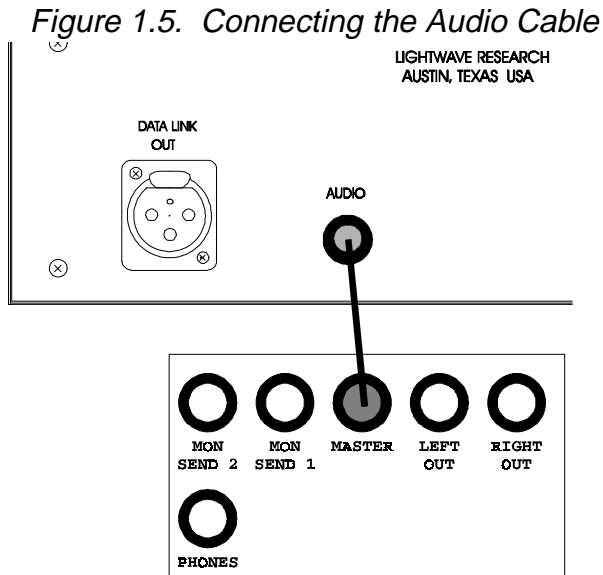

**Caution:** Never connect a speaker level signal (cable from an amplifier output) to the Audio input on the *Mini Controller*. Component damage will occur and this action will void your Warranty! The line level should be from 100 mV to a maximum of 1 V peak to peak.

**Note:** a built in summing circuit combines the left and right signals together.

Apply power to the *Mini Controller* and *AF1000* strobes. Installation and setup is now complete. If you are experiencing any problems, refer to *Appendix A* for possible solutions. If you can not resolve the problem yourself, contact High End Systems Technical Support.

# Chapter 2

## Mini Controller Operation

*In this chapter you will:*

- learn to operate the Mini Controller*
- learn how to select the desired program*
- learn about the Mini Controller's special features*
- learn how to change the Rate, Intensity, and Audio programs to cater to your needs*

### Overview

---

This Chapter covers the operation of the *Mini Controller* and the functions of the keys. There are four groups of programs installed on the EPROM in the *Mini Controller*: Standard Programs, Random Function Programs, Advance Programs, and Lightning Programs. Each program's Rate and Intensity may be manipulated to cater to individual needs. Also, audio synchronization functions are available to trigger the ignition of the *AF1000* strobes. Complete program layout and explanations are included at the end of this manual in the *Addendum*. The *Addendum* will take precedence over program information contained in this Chapter.

**Note:** any changes made to the Intensity, Rate, and Audio parameters are applied globally to all programs. If you turn the Intensity down to 15, that Intensity will effect all programs when they are run.

### Operating Process

---

The operating process of the *Mini Controller* is based upon Programs. The Programs consist of steps. A step an instruction sent to the strobes which tells which strobe(s) to illuminate, the duration of the illumination, and the Intensity of the illumination. A group of steps forms a sequence. The time it takes for one step to advance to another step is Rate. Refer to Figure 2.1.

Figure 2.1. Mini Controller Operation Process

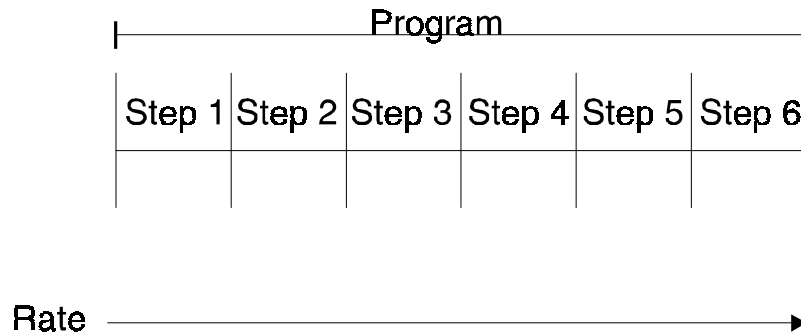

When a Program is run, it is run from the first step to the last step. Then the Program will loop back to the first step and begin this process again.

## Standby Mode

---

When power is first applied to the unit or when the unit is reset, Standby Mode is automatically engaged. The *Mini Controller* is in Standby Mode when the LED above the <STANDBY> key is illuminated. Standby mode is used to allow the desired program to be located without starting any other program. After you have reached the desired Program (refer to the *Program* topic found later in this Chapter), press the <STANDBY> key to disable Standby Mode and start the desired program. When you wish to stop the current program, press the <STANDBY> key again.

## Flash Mode

---

A special feature of the *Mini Controller* is Flash Mode. Hold the <flash> key down to ignite all *AF1000* strobes at full Intensity for .125 seconds (60 Hz) or .15 seconds (50 Hz). The <flash> key may be pressed repeatedly or until the strobe(s) time out, at which point the LEDs will continue to flash, but the strobes will not respond until they have finished their cooling cycle . Flash Mode will override any program that is currently being run, with the exception of the *Lightning Programs*. Refer to *Lightning Programs* later in this Chapter.

## Program Mode

---

Press the <program> key to enable Program Mode (the *Mini Controller* defaults to Program Mode). Program Mode is engaged when the LED above the <program> key is illuminated. The <program> key and the up/down arrow keys allow access to the Standard Programs, Random Function Programs, Advance Programs, and Lightning Programs.

## Program Hold

---

Program Hold allows another program to be selected without affecting the current program being run. Program Hold is initiated by holding down the <program> key and using the arrow keys to pre-select another program. The Program Hold Indicator (LED between the 7-segment LEDs in the value display) will illuminate to confirm this mode is active. The next program will not begin until the <program> key is released.

## Program Select Return

---

Twelve seconds after adjusting the Rate, Intensity, or Audio setting, the controller will return to Program Mode. Any changes made to the above settings will be in effect.

## Standard Programs

---

The number of Standard Programs the *Mini Controller* can use depends on the number of channels that are set up. Refer to Table 2.1.

Table 2.1: Standard Programs Per Channel

Number of Channels	Number of Programs
1	6
2	12
3	24
4	23
5	27
6	27
7	27
8	27
9	27
10	27
11	27
12	27

## Random Function Programs

---

Immediately following the Standard Programs are three Random Function Programs. This set of programs is not dependant upon the number of assigned channels. Random Function Programs are annotated by F 1 , F 2 , and F 3 on the value display. This set of programs perform the following actions:

- F 1 –multiple fixtures will flash in a random pattern, but only one fixture will flash at maximum Intensity at a time.
- F 2 –single fixtures will flash in a random pattern and randomly go to full Intensity.
- F 3 –all fixtures will flash in a random pattern, one fixture at a time (sequentially) at random intensities.

## Advance Programs

---

Following the Random Function Programs are the Advance Programs. The Advance Programs are annotated by A 1 through A 8 on the display. Advance Programs will randomly select from the available Standard Programs (refer to Table 2.1 for the available programs per channels). A 1 is the fastest Rate of program advancement and A 8 is the slowest Rate of program advancement.

## Lightning Programs

---

The final set of programs are the Lightning Programs. These programs were specifically designed to emulate ground to cloud and inner cloud lighting at various distances. They are annotated by L 1 through L 7 on the display. The Lightning Programs operate differently from the previous programs. You may start and stop a Lighting Program three ways:

- hold the <flash> key down to begin the program and release the key to stop the program.
- press the <STANDBY> key (take the *Mini Controller* off Standby Mode) to begin the program and press the key again to turn Standby Mode on again and stop the program.
- by using Audio parameter 9 and an audio signal to trigger the start of the Lightning Program. Refer *Audio Mode* found later in this Chapter for further clarification.

Refer to the *Addendum* for the descriptions of the Lightning programs.

## Intensity

---

The <intensity> key changes the brightness of the *AF1000* strobes. There are three sets of Intensity parameters: Incremental, Program Functions, and Function Advance.

### Incremental

---

There are 64 Incremental Intensity parameters. These parameters are annotated on the display by 1 through 64, with 1 being the dimmest and 64 being the brightest.

### Program Function

---

Following the Incremental parameters, there are seven Program Function parameters. Refer to Table 2.2 and the *Addendum* for the effect of each Program Function.

Table 2.2: Intensity Program Functions

Program Function	Manipulation of Intensity
F 1	Ramp down
F 2	Ramp up
F 3	Ramp up and down
F 4	Random—changes every time a program is run
F 5	Maximum Intensity for one run of the program, then minimum Intensity for the next run of a program
F 6	Maximum Intensity for two steps, then minimum Intensity for the next two steps
F 7	Maximum Intensity for one step, then minimum Intensity for one step

### Function Advance

---

The last Intensity parameter is Function Advance. Function Advance is annotated by *FA* on the display. When this parameter is selected, a Program Function (F 1 – F 7) is used at random and an Intensity of 64 is used fifty percent of the time.

## Rate

---

The <rate> key allows access to the Rate at which the controller advances steps within every program. There are three sets of Rate parameters: Incremental, Program Functions, Function Advance.

### Incremental

---

There are 99 Incremental parameters for Rate. These parameters are annotated on the display by 1 through 99, with 1 being the slowest Rate and 99 being the fastest Rate.

### Program Function

---

Following the Incremental parameters, there are seven Program Function parameters. Refer to Table 1.2 and the *Addendum* for the result of each Program Function.

Table 2.3: Rate Program Functions

Program Function	Manipulation of Rate
F 1	Ramp down
F 2	Ramp up
F 3	Ramp up and down
F 4	Fast for two programs, then slow for one programs
F 5	Fast for twelve steps, then slow for four steps
F 6	One step fast, next step slow
F 7	Small pause every five steps

### Function Advance

---

The last Rate parameter is Function Advance. Function Advance is annotated by F A on the display. When this parameter is selected a Program Function (F 1 –F 7) is used at random or a Rate of 99 is used fifty percent of the time.

## Audio Mode

The Audio feature allows audio triggering and synchronization control of the AF1000 strobes. Press the <audio> key and use the arrow keys to maneuver through the audio parameters.

**Note:** if any of the following parameters are selected, Audio Mode will disable itself (- -) so it will not to conflict with any actions of these parameters:

- Advance Programs (A 1 through A 8 ) in Program Mode.
- Program Function in Rate Mode and Intensity Mode.
- Function Advance in Rate or Intensity Mode.

### Audio Parameters

There are five sets of audio parameters. Refer to Figure 2.1 and the *Addendum* for clarification of Audio parameters.

Figure 2.1. Audio Parameter Display

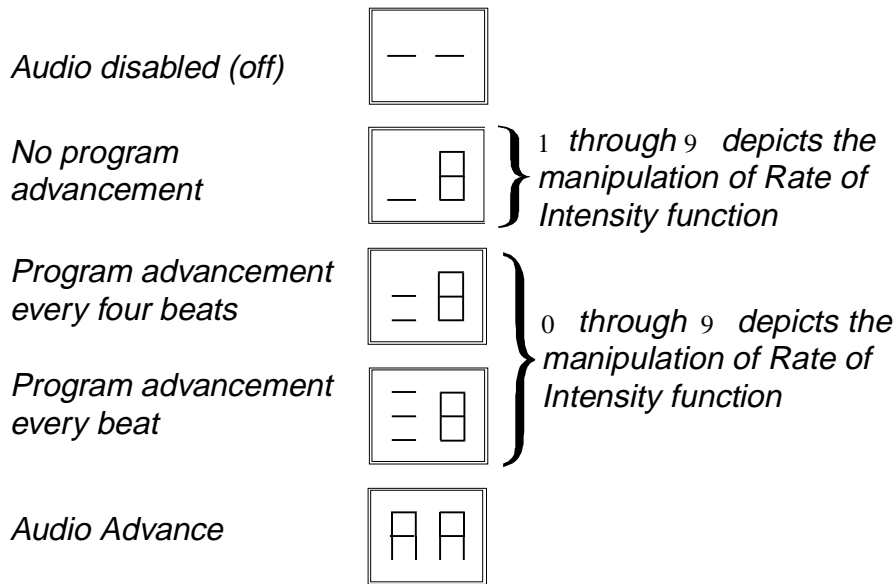

The audio settings are:

- Two side by side horizontal bars– the Audio Mode is disabled and Audio Rate or Intensity functions are not available (default).
- One horizontal bar– no program advancement, but the audio rate or intensity manipulation functions are available (refer to the following section).
- Two horizontal bars– programs will advance randomly with every four beats.
- Three horizontal bars– programs will advance randomly with every beat.
- Audio Advance (A A )– programs will randomly advance to a different Audio Mode every eight seconds.

## Audio Rate or Intensity Manipulation

---

Within each audio parameter, there are nine functions for Program, Rate and Intensity manipulation. These functions are annotated as 0 through 9 on the display. Refer to Table 2.3 and the *Addendum* for the purpose of these functions.

Table 2.4: Audio Rate or Intensity Manipulation Functions

Function Number	Manipulation of Rate or Intensity
0	no manipulation
1	frame advancing on beat
2	four frames advance per beat
3	beat causes maximum Rate, otherwise Rate equals medium
4	beat causes maximum Rate, otherwise Rate taper down
5	maximum Intensity on beat, then Intensity tapers down
6	minimum Intensity on beat, then Intensity tapers up
7	Intensity flips between maximum and medium on beat
8	maximum Intensity on beat, otherwise medium Intensity
9	resets program to first step on beat

**Note:** Audio Function 9 will override Standby Mode when used with a Lightning Program.

# Appendix A

## Troubleshooting and Maintenance

This *Appendix* provides directions for troubleshooting problems that may have occurred from improper setup or configuration of the *Mini Controller* and the *AF1000* strobes. Before calling for technical assistance, follow the recommended procedures in this *Appendix* to solve many of the common possible problems.

If the procedures in this *Appendix* do not solve your problem and you need to call for assistance, please provide the support technician with the information outlined in the Support Checklist provided in this *Appendix*.

A

### Support Checklist

---

Technical support can provide you with faster service if you can give the technician the following information when you call.

- Customer name
- Country, if other than U.S.A.
- Phone number and Fax number
- The Mini Controller's ROM version (procedure found later in this *Appendix* under *Mini Controller's ROM Version*)
- A description of your problem and the troubleshooting procedures that you have already performed to resolve your problem
- The type of XLR cables that you are using? Were they purchased or built?

## Possible Problems and Solutions

Use the following *Table* to solve most problems.

*Table A.1: Trouble Shooting Solutions*

<b>Problem</b>	<b>Probable Cause</b>	<b>Solution</b>
LEDs will not turn on	no power to controller	apply power
LEDs will not turn on	internal fuse blown	call High End Systems Technical Support for service instructions
Some fixtures not responding to Controller	configuration DIP switches not set for correct number of fixtures	reset controller to the correct number of DIP switches
Fixtures not responding to Controller	internal fuse(s) blown	call High End Systems Technical Support for service instructions
Fixtures not responding to Controller	no power to fixtures	apply power to fixtures
Fixtures not responding to Controller	bad XLR cable(s)	check all XLR cables with a Volt Ohm meter by placing leads on each pin at both cable ends and check for resistance— replace cables as needed
Fixtures not responding to Controller	Fixture addresses have not been set	Refer to Table 1.2 in Chapter 1 to properly set fixture addresses
Controller displays C F	configuration DIP switches not set	reset controller to the correct number of DIP switches
Fixture's Intensity and Rate settings are swapped	Fixture is set to an even DMX channel	Reset fixture to correct DMX channel
When the <flash> key is used, the fixture's duration lasts for well over the correct time (about 2 seconds)	fixture is set for 3-channel DMX mode	reset Personality switches <3> and <4> to the On position, leave <5> off
Some fixture(s) behave differently than others	some fixtures are set for 3-channel DMX mode	reset Personality switches <3> and <4> to the On position, leave <5> Off

Table A.1: Trouble Shooting Solutions

Problem	Probable Cause	Solution
Audio indicator does not light up	weak or no audio signal	check to ensure cable is properly connected, boost audio signal (between 20 Hz to 100 Hz)
Audio indicator does not light up	bad audio cable	check the tip, ring, and sleeve resistance with a Volt Ohm meter—replace or repair cable
Audio indicator does not light up	a speaker level signal has been sent to the audio connector	contact High End Systems Technical Support
Audio indicator constantly stays on	audio signal is too strong	reduce audio signal



## Mini Controller Reset

---

The *Mini Controller* may be reset two different ways:

- press the <program>, <intensity>, <rate>, and <audio> keys simultaneously
- turn the configuration DIP switch to the Off position and return it to the On position

**Note:** when the Mini Controller is reset, all default values will be in effect and Standby Mode will be engaged.

## Mini Controller ROM Version Number

---

To view the ROM version number, turn the Configuration Dip switch to the Off position and press any key. The ROM version number will appear on the display.

## General Maintenance and Cleaning

---

You should clean your *Mini Controller* on a regular basis. Dust and dirt can accumulate and cause malfunctions. As a precautionary step, unplug the *Mini Controller* before cleaning. To clean the outer surfaces:

- Wipe with a soft cloth or tissue, or use a small vacuum to remove the built-up dust and dirt. Do not use a blower, as this will force dirt into the controller.



**Warnings:** Do not submerge in liquid. There are no user serviceable parts inside. Servicing should only be conducted by a qualified technician.



# ***Appendix B***

## ***Warranty Information***

### **Limited Warranty**

Unless otherwise stated, your product is covered by a one year parts and labor limited warranty. If the warranty registration form provided with this equipment is filled out and faxed or mailed to High End Systems, Inc., and received within 60 days of invoice date, the one year parts and labor limited warranty will be extended one additional year, for a total of two years. Dichroic filters and Lithopatterns™ are not guaranteed against breakage or scratches to coating. It is the owner's responsibility to furnish receipts or invoices for verification of purchase, date, and dealer or distributor. If purchase date cannot be provided, date of manufacture will be used to determine warranty period.

**B**

### **Returning an Item Under Warranty for Repair**

It is necessary to obtain a Return Authorization Number (RA#) from your dealer/point of purchase BEFORE any units are returned for repair. The manufacturer will make the final determination as to whether or not the unit is covered by warranty. Lamps are covered by the lamp manufacturer's warranty.

Any Product unit or parts returned to High End Systems must be packaged in a suitable manner to ensure the protection of such Product unit or parts, and such package shall be clearly and prominently marked to indicate that the package contains returned Product units or parts and with a Returned Authorization (RA#) number. Accompany all returned Product units or parts with a written explanation of the alleged problem or malfunction.

Please note: Freight Damage Claims are invalid for fixtures shipped in non-factory boxes and packing materials.

### **Freight**

All shipping will be paid by the purchaser. Items under warranty shall have return shipping paid by the manufacturer only in the Continental United States. Under no circumstances will freight collect shipments be accepted. Prepaid shipping does not include rush expediting such as airfreight. Airfreight can be sent customer collect in the Continental United States.

REPAIR OR REPLACEMENT AS PROVIDED FOR UNDER THIS WARRANTY IS THE EXCLUSIVE REMEDY OF THE CONSUMER. HIGH END SYSTEMS, INC. MAKES NO WARRANTIES, EXPRESSED OR IMPLIED, WITH RESPECT TO ANY PRODUCT, AND HIGH END SPECIFICALLY DISCLAIMS ANY WARRANTY OF MERCHANTABILITY OR FITNESS FOR A PARTICULAR PURPOSE. HIGH END SHALL NOT BE LIABLE FOR ANY INDIRECT, INCIDENTAL, OR CONSEQUENTIAL DAMAGE, INCLUDING LOST PROFITS, SUSTAINED OR INCURRED IN

CONNECTION WITH ANY PRODUCT OR CAUSED BY PRODUCT DEFECTS OR THE PARTIAL OR TOTAL FAILURE OF ANY PRODUCT REGARDLESS OF THE FORM OF ACTION, WHETHER IN CONTRACT, TORT, (INCLUDING NEGLIGENCE), STRICT LIABILITY, OR OTHERWISE, AND WHETHER OR NOT SUCH DAMAGE WAS FORESEEN OR UNFORESEEN.

Warranty is void if the product is misused, damaged, modified in any way, or for unauthorized repairs or parts. This warranty gives you specific legal rights, and you may also have other rights which vary from state to state.

# Addendum

This *Addendum* provides you with a listing of the current programs that are pre-installed on your *Mini Controller*. This *Addendum* will take precedence over any program information provided in the *User's Manual*. Use the tables in the following sections for the description, location of available programs, and parameters of the *Mini Controller*.

## Program Mode

---

This section provides reference tables to view the number of available programs you have available based upon the number of connected *AF1000* luminaires.

### Standard Programs

---

*Table ADM.1: Available Programs for One Fixture*

Display	Steps	Description
1	1	flash minimum duration
2	2	flash maximum duration
3	2	pop and drop
4	2	ramp up and down, Intensity increments by 1
5	2	ramp up and down, Intensity increments by 2
6	1	full on

ADM

*Table ADM.2: Available Programs for Two Fixtures*

<b>Display</b>	<b>Steps</b>	<b>Description</b>
1	1	all flash minimum duration
2	2	all flash maximum duration
3	2	single fixture chase minimum duration
4	2	single fixture chase maximum duration
5	4	individual ramp up and down with Intensity incrementing by 4
6	4	individual ramp up and down with Intensity incrementing by 2
7	2	crossfade between fixtures
8	4	pop and drop
9	3	fixture overlap with maximum duration
1 0	4	individual ramp up and down
1 1	2	ramp up and down with Intensity increments of 1
1 2	1	full on

*Table ADM.3: Available Programs for Three Fixtures*

<b>Display</b>	<b>Steps</b>	<b>Description</b>
1	1	all flash minimum duration
2	2	all flash maximum duration
3	3	single fixture chase minimum duration
4	3	single fixture chase minimum duration, reverse direction
5	3	single fixture chase maximum duration
6	3	single fixture chase maximum duration, reverse direction
7	6	individual ramp up and down with Intensity incrementing by 4
8	6	individual ramp up and down with Intensity incrementing by 4, reverse direction
9	6	individual ramp up and down with Intensity incrementing by 2
1 0	6	individual ramp up and down with Intensity incrementing by 2, reverse direction
1 1	3	crossfade
1 2	3	crossfade, reverse direction
1 3	2	two to one fixture crossfade
1 4	6	pop and drop
1 5	6	inverted pop and drop
1 6	3	two fixtures overlap, maximum duration
1 7	3	two fixture overlap, maximum duration, reverse direction
1 8	6	individual ramp up and down with background
1 9	6	inverted individual ramp up and down with background
2 0	2	all ramp up and down with Intensity increments of 1
2 1	4	single fixture bounce
2 2	3	two fixture bounce and latch, maximum Rate, maximum Intensity
2 3	3	two fixture bounce, slightly slower Rate (than 23), maximum Intensity
2 4	1	full on



*Table ADM.4: Available Programs for Four Fixtures*

<b>Display</b>	<b>Steps</b>	<b>Description</b>
1	1	all flash minimum duration
2	2	all flash maximum duration
3	4	single fixture chase minimum duration
4	4	single fixture chase minimum duration, reverse direction
5	4	single fixture chase maximum duration
6	4	single fixture chase maximum duration, reverse direction
7	8	individual ramp up and down with Intensity incrementing of 4
8	8	individual ramp up and down with Intensity incrementing by 4, reverse direction
9	8	individual ramp up and down with Intensity incrementing by 2
1 0	6	individual ramp up and down with Intensity incrementing by 2, reverse direction
1 1	4	crossfade
1 2	8	two fixture crossfade
1 3	8	pop and drop
1 4	4	pop and drop, reverse direction
1 5	4	two fixture overlap, maximum duration
1 6	8	two fixture overlap, maximum duration, reverse direction
1 7	6	individual ramp up and down with background
1 8	6	inverted individual ramp up and down with background
1 9	2	ramp up and down with Intensity increments of 1
2 0	4	single fixture bounce
2 1	3	bounce maximum rate, maximum Intensity
2 2	3	bounce slower Rate (than 23), maximum Intensity
2 3	1	full on

*Table ADM.5: Available Programs for Five Fixtures*

<b>Display</b>	<b>Steps</b>	<b>Description</b>
1	1	all flash minimum duration
2	2	all flash maximum duration
3	5	single fixture chase minimum duration
4	4	single fixture chase minimum duration, reverse direction
5	5	single fixture chase maximum duration
6	5	single fixture chase maximum duration, reverse direction
7	10	individual ramp up and down with Intensity incrementing of 4
8	10	individual ramp up and down with Intensity incrementing by 4, reverse direction
9	10	multiple fixtures ramp up and down, with Intensity incrementing by 2
1 0	10	ramp up and down, with Intensity incrementing by 2, in reverse direction
1 1	5	crossfade
1 2	3	two fixture crossfade
1 3	10	pop and drop
1 4	10	pop and drop, reverse direction
1 5	5	two fixture overlap, maximum duration
1 6	5	two fixture overlap, maximum duration, reverse direction
1 7	3	two fixture chase at two fixture stager, maximum duration
1 8	3	two fixture chase at two fixture stager, maximum duration, reverse direction
1 9	10	individual ramp up and down with background
2 0	2	individual ramp up and down with background, reverse direction
2 1	4	all ramp up and down
2 2	3	single fixture bounce
2 3	3	two fixture bounce and latch, maximum rate, maximum Intensity
2 4	4	two fixture bounce slightly, slower rate (than 23)
2 5	1	full on
2 6	5	rocket
2 7	4	rocket, reverse direction



*Table ADM.6: Available Programs for Six Fixtures*

<b>Display</b>	<b>Steps</b>	<b>Description</b>
1	1	all flash minimum duration
2	2	all flash maximum duration
3	6	single fixture chase minimum duration
4	6	single fixture chase minimum duration, reverse direction
5	6	single fixture chase maximum duration
6	6	single fixture chase maximum duration, reverse direction
7	12	individual ramp up and down
8	12	individual ramp up and down, reverse direction
9	12	ramp up and down, with Intensity incrementing by 2
10	10	multiple fixtures ramp up and down, Intensity incrementing by 2, reverse direction
11	5	crossfade
12	3	multiple fixture crossfade
13	12	pop and drop
14	12	pop and drop, reverse direction
15	6	two fixture overlap, maximum duration
16	6	two fixture overlap, maximum duration, reverse direction
17	3	two fixture chase, two fixture stager, maximum duration
18	3	two fixture chase, two fixture stager, maximum duration reverse direction
19	12	individual ramp up and down with background
20	12	individual ramp up and down with background, reverse direction
21	2	all ramp up and down
22	10	single fixture bounce
23	3	two fixture bounce and latch, maximum rate, maximum Intensity
24	3	two fixture slightly slower rate (than 23), maximum Intensity
25	1	full on
26	6	rocket
27	4	rocket, reverse direction

*Table ADM.7: Available Programs for Seven Fixtures*

<b>Display</b>	<b>Steps</b>	<b>Description</b>
1	1	all flash minimum duration
2	2	all flash maximum duration
3	7	single fixture chase minimum duration
4	7	single fixture chase minimum duration, reverse direction
5	7	single fixture chase maximum duration
6	7	single fixture chase maximum duration, reverse direction
7	14	individual ramp up and down
8	14	individual ramp up and down, reverse direction
9	14	individual ramp up and down, Intensity incrementing by 2
1 0	14	individual ramp up and down, with Intensity incrementing by 2 individual ramp up and down, reverse direction
1 1	7	crossfade
1 2	4	multiple fixture crossfade
1 3	14	pop and drop
1 4	14	pop and drop, reversed
1 5	7	two fixture overlap, maximum duration
1 6	7	two fixture overlap, maximum duration, reverse direction
1 7	4	two fixture chase, two fixture stager, maximum duration
1 8	4	two fixture chase, two fixture stager, maximum duration, reverse direction
1 9	14	individual ramp up and down with background
2 0	14	individual ramp up and down with background, reverse direction
2 1	2	all ramp up and down
2 3	12	single fixture bounce
2 3	5	two fixture bounce and latch maximum rate, maximum Intensity
2 4	5	two fixture slightly slower Rate (than 23), maximum Intensity
2 5	1	full on
2 6	7	rocket
2 7	7	rocket, reverse direction



*Table ADM.8: Available Programs for Eight Fixtures*

<b>Display</b>	<b>Steps</b>	<b>Description</b>
1	1	all flash minimum duration
2	2	all flash maximum duration
3	8	single fixture chase minimum duration
4	8	single fixture chase minimum duration, reverse direction
5	8	single fixture chase maximum duration
6	8	single fixture chase maximum duration, reverse direction
7	16	individual ramp up and down
8	16	individual ramp up and down, reverse direction
9	16	individual ramp up and down, Intensity incrementing by 2
1 0	10	individual fixtures ramp up and down, Intensity incrementing by 2, reverse direction
1 1	5	crossfade
1 2	4	multiple fixture crossfade
1 3	16	pop and drop
1 4	16	pop and drop, reversed
1 5	8	two fixture overlap, maximum duration
1 6	8	two fixture overlap, maximum duration, reverse direction
1 7	3	three fixture chase, two fixture stager, maximum duration
1 8	3	three fixture chase, two fixture stager, maximum duration, reverse direction
1 9	16	individual ramp up and down with background
2 0	16	individual ramp up and down with background, reverse direction
2 1	2	all ramp up and down
2 2	1	single fixture bounce
2 3	14	two fixture bounce and latch, maximum rate, maximum intensity
2 4	5	two fixture bounce, slightly slower rate (than 23), maximum intensity
2 5	2	full on
2 6	8	rocket
2 7	8	rocket, reverse direction

*Table ADM.9: Available Programs for Nine Fixtures*

<b>Display</b>	<b>Steps</b>	<b>Description</b>
1	1	all flash minimum duration
2	2	all flash maximum duration
3	9	single fixture chase minimum duration
4	9	single fixture chase minimum duration, reverse direction
5	9	single fixture chase maximum duration
6	9	single fixture chase maximum duration, reverse direction
7	18	individual ramp up and down
8	18	individual ramp up and down, reverse direction
9	18	multiple fixtures ramp up and down, Intensity incrementing by 2
1 0	18	multiple fixtures ramp up and down, ignite twice with Intensity incrementing by 2 individual ramp up and down, reverse direction
1 1	9	crossfade
1 2	5	multiple fixture crossfade
1 3	18	pop and drop
1 4	18	pop and drop, reversed
1 5	9	two fixture overlap, maximum duration
1 6	9	two fixture overlap, maximum duration, reverse direction
1 7	3	three fixture chase, two fixture stager, maximum duration
1 8	3	three fixture chase, two fixture stager maximum duration, reverse direction
1 9	16	individual ramp up and down with background
2 0	16	individual ramp up and down with background, reverse direction
2 1	2	all ramp up and down
2 2	16	single fixture bounce
2 3	5	two fixture maximum Rate, maximum Intensity
2 4	5	two fixture slightly slower Rate (than 23), maximum Intensity
2 5	1	full on
2 6	10	rocket
2 7	10	rocket, reverse direction



*Table ADM.10: Available Programs for Ten Fixtures*

<b>Display</b>	<b>Steps</b>	<b>Description</b>
1	1	all flash minimum duration
2	2	all flash maximum duration
3	10	single fixture chase minimum duration
4	10	single fixture chase minimum duration, reverse direction
5	10	single fixture chase maximum duration
6	10	single fixture chase maximum duration, reverse direction
7	20	individual ramp up and down
8	20	individual ramp up and down, reverse direction
9	20	individual ramp up and down, Intensity incrementing by 2
1 0	20	individual ramp up and down, Intensity incrementing by 2, in reverse direction
1 1	10	crossfade
1 2	5	multiple fixture crossfade
1 3	20	pop and drop
1 4	20	pop and drop, reverse direction
1 5	10	two fixture overlap, maximum duration
1 6	10	two fixture overlap, maximum duration, reverse direction
1 7	10	four fixture chase maximum duration
1 8	3	four fixture chase, maximum duration, reverse direction
1 9	20	individual ramp up and down with background
2 0	20	individual ramp up and down with background, reverse direction
2 1	2	all ramp up and down
2 2	18	single fixture bounce
2 3	5	two fixture bounce and latch, maximum Rate, maximum Intensity
2 4	5	two fixture bounce, slightly slower rate (than 23), maximum Intensity
2 5	1	full on
2 6	10	rocket
2 7	10	rocket, reverse direction

*Table ADM.11: Available Programs for Eleven Fixtures*

<b>Display</b>	<b>Steps</b>	<b>Description</b>
1	1	all flash minimum duration
2	2	all flash maximum duration
3	11	single fixture chase minimum duration
4	11	single fixture chase minimum duration, reverse direction
5	11	single fixture chase maximum duration
6	11	single fixture chase maximum duration, reverse direction
7	22	individual ramp up and down
8	22	individual ramp up and down, reverse direction
9	22	individual ramp up and down, Intensity incrementing by 2
1 0	22	individual ramp up and down, Intensity incrementing by 2, reverse direction
1 1	11	crossfade
1 2	6	multiple fixture crossfade
1 3	22	pop and drop
1 4	22	pop and drop, reversed
1 5	11	two fixture overlap, maximum duration
1 6	11	two fixture overlap, maximum duration, reverse direction
1 7	3	three step chase
1 8	3	three step chase, in reverse direction
1 9	22	individual ramp up and down with background
2 0	20	individual ramp up and down with background, reverse direction
2 1	2	all ramp up and down
2 2	20	single fixture bounce
2 3	5	two fixture bounce and latch, maximum Rate, maximum Intensity
2 4	5	two fixture bounce slightly slower Rate (than 23), maximum Intensity
2 5	1	full on
2 6	12	rocket
2 7	12	rocket, reverse direction



*Table ADM.12: Available Programs for Twelve Fixtures*

<b>Display</b>	<b>Steps</b>	<b>Description</b>
1	1	all flash minimum duration
2	2	all flash maximum duration
3	12	single fixture chase minimum duration
4	12	single fixture chase minimum duration, reverse direction
5	12	single fixture chase maximum duration
6	12	single fixture chase maximum duration, reverse direction
7	24	individual ramp up and down
8	24	individual ramp up and down, reverse direction
9	24	individual ramp up and down, Intensity incrementing by 2
1 0	24	individual ramp up and down, Intensity incrementing by 2, reverse direction
1 1	12	crossfade
1 2	6	multiple fixture crossfade
1 3	24	pop and drop
1 4	24	pop and drop, reversed
1 5	12	two fixture overlap, maximum duration
1 6	12	two fixture overlap, maximum duration, reverse direction
1 7	3	three step chase
1 8	3	three step chase, in reverse direction
1 9	24	individual ramp up and down with background
2 0	24	individual ramp up and down with background, reverse direction
2 1	2	all ramp up and down
2 2	22	single fixture bounce
2 3	6	two fixture bounce and latch, maximum Rate, maximum Intensity
2 4	6	two fixture bounce slightly slower Rate (than 2 3 ), maximum Intensity
2 5	1	full on
2 6	12	rocket
2 7	12	rocket, reverse direction

## Random Function Programs

---

*Table ADM.13: Random Functions*

Display	Description
F 1	multiple fixtures will flash in a random pattern, but only one fixture will flash at maximum Intensity at a time
F 2	single fixtures will flash in a random pattern and randomly go to full Intensity
F 3	all fixtures will flash in a random pattern, one fixture at a time (sequentially) at random intensities

## Advance Programs

---

*Table ADM.14: Advance Programs*

Display	Description
A 1 - A 8	Standard Programs are randomly selected. A 1 is the fastest rate that the programs will advance and A 8 is the slowest rate that the programs will advance.



## Lightning Programs

---

*Table ADM.15: Lightning Programs*

Display	Steps	Description
L 1	26	clap–initial big bolt at top, flickers out at end
L 2	29	heat–low to moderate inner cloud lightning
L 3	25	peal–ground to cloud lightning, high activity, energy focused in three main channels
L 4	25	close strike–storm overhead, moderate to high activity
L 5	17	near–moderate activity, two channel lightning, flickers in distance
L 6	48	distant–moderate activity, constant flickering cloud lightning
L 7	25	pearl–big flash followed by back to back flashes of moderate intensity

## Intensity Parameters

---

Use the following table for the descriptions of the parameters available through the <intensity> key.

*Table ADM.16: Intensity Parameters*

Display	Description
1 – 6 4	1 is the dimmest intensity and 6 4 is the brightest .
F 1	ramp down
F 2	ramp down
F 3	ramp up and down
F 4	random–changes every time a program is run
F 5	maximum Intensity for one sequence, then minimum Intensity for the next program run
F 6	maximum Intensity for two steps, then minimum Intensity for the next two steps
F 7	maximum intensity for one step, then minimum Intensity for one step
F A	randomly selects F 1 –F 7 and randomly uses a value of 6 4 fifty percent of the time

## Rate Parameters

---

Use the following table for the descriptions available through the <rate> key.

*Table ADM.17: Rate Parameters*

Display	Description
1 - 9 9	1 is the slowest Rate and 9 9 is the fastest rate
F 1	ramp down
F 2	ramp up
F 3	ramp up and down
F 4	fast for two program programs, then slow for one program
F 5	fast for twelve steps, then slow for four steps
F 6	one step fast, next step slow
F 7	small pause every five steps
F A	randomly selects F 1 –F 7 and randomly uses a value of 9 9 fifty percent of the time

## Audio Parameters

---

Use the following table for the description of the parameters available through the <audio> key.

*Table ADM.18: Audio Parameters*

Display	Description
--	Audio mode is disabled
_ 1	no program advancement, step advancing on beat
_ 2	no program advancement, four steps advanced per beat
_ 3	no program advancement, beat causes maximum Rate, otherwise Rate is medium
_ 4	no program advancement, beat causes maximum Rate, tapers down after beat
_ 5	no program advancement, beat causes maximum Intensity, tapers down after beat
_ 6	no program advancement, no program advancement, beat causes minimum Intensity, tapers up after beat
_ 7	no program advancement, Intensity flips between maximum and medium on beat
_ 8	no program advancement, beat causes maximum intensity, otherwise intensity is medium
_ 9	no program advancement, beat causes program to reset to the first step
= 0	program advancement every four beats
= 1	program advancement every four beats, step advancing on beat
= 2	program advancement every four beats, four steps advanced per beat
= 3	program advancement every four beats, beat causes maximum Rate, otherwise Rate is medium
= 4	program advancement every four beats, no program advancement, beat causes maximum Rate, tapers down after beat
= 5	program advancement every four beats, no program advancement, beat causes maximum Intensity, tapers down after beat
= 6	program advancement every four beats, beat causes minimum Intensity, tapers up after beat
= 7	program advancement every four beats, Intensity flips between maximum and medium on beat
= 8	program advancement every four beats, beat causes maximum Intensity, otherwise Intensity is medium

**ADM**

<b>Display</b>	<b>Description</b>
= 9	program advancement every four beats, beat causes program to reset to the first step
≡0	program advancement every beat
≡1	program advancement every beat, step advancing on beat
≡2	program advancement every beat, four steps advanced per beat
≡3	program advancement every beat, beat causes maximum Rate, otherwise Rate is medium
≡4	program advancement every beat, no program advancement, beat causes maximum Rate, tapers down after beat
≡5	program advancement every beat, beat causes maximum Intensity, tapers down after beat
≡6	program advancement every beat, beat causes minimum Intensity, tapers up after beat
≡7	program advancement every beat, Intensity flips between maximum and medium on beat
≡8	program advancement every beat, beat causes maximum intensity, otherwise intensity is medium
≡9	program advancement every beat, beat causes program to reset to the first step
A A	a different Audio Mode is randomly selected every eight seconds